

MINI CARREGADORA



E a sua obra não pára.
www.joseruela.pt



Peso **Kg.2.000**
Weight **Kg.2.000**



Carico operativo **Kg.550**
Operating capacity **Kg.550**



Potenza motore **HP 34**
Engine power **HP 34**

Macchina compatta stabile di grande versatilità.

Stable compact machine with great versatility.

Machine compacte, stable, extrêmement polyvalente.

Kompaktlader, stabil und vielseitig einsetzbar.



Peso **Kg. 2.700**
Weight **Kg. 2.700**



Carico operativo **Kg.680**
Operating capacity **Kg.680**



Potenza motore **HP 58**
Engine power **HP 58**

Macchina potente stabile ideale per ogni servizio.

Powerful machine stable and ideal for every service.

Machine puissante, stable, idéale pour toutes sortes de travail.

Kompaktlader, stabil und leistungsstark für jeden Einsatz.

635

865

755

985

MINI pale compatte MINI pale compatte



Peso **Kg.2.500**
Weight **Kg.2.500**



Carico operativo **Kg.612**
Operating capacity **Kg.612**



Potenza motore **HP 46**
Engine power **HP 46**

Macchina che unisce i bassi costi di esercizio ad un'alta produttività.

Machine that joins both low operating costs to a high productivity.

Machine aillant des frais de gestion peu élevés et un grand rendement.

Kompaktlader, niedrige Arbeitskosten und hohe Produktivität.



Peso **Kg. 3.150**
Weight **Kg. 3.150**



Carico operativo **Kg.908**
Operating capacity **Kg.908**



Potenza motore **HP 86**
Engine power **HP 86**

Macchina di dimensioni considerevoli, potente, ideale come macchina porta attrezzi.

Machine of considerable dimensions, powerful, and ideal for accessories.

Machine de grosse taille, puissante, idéale comme machine porte-outils.

Kompaktlader, obere Leistungsklasse, ideal für diverse Anbaugeräte.



José Ruela, Lda.

Estrada de Manique, 19 · 1750-166 LISBOA

Tel.: 217 542 320 (Chamada para rede fixa nacional)

aluguer@joseruela.pt · www.joseruela.pt

MINI-PÁS
DE RODAS



MINI pale compacte

SKID steer loaders MINI chargeurs KOMPAKTlader



José Ruela, Lda.

Estrada de Manique, 19 · 1750-166 LISBOA

Tel.: 217 542 320 (Chamada para rede fixa nacional)

aluguer@joseruela.pt · www.joseruela.pt



Posto operatore ben accessibile e di buon riparo.

Operators place with good accessibility and protection.

Poste opérateur accessible et offrant une bonne protection.

Arbeitsplatz mit guter Zugänglichkeit und mit gutem Schutz.



Cabina ribaltabile con bloccaggi di sicurezza.

Overturnable cabin with security blockage.

Cabine rabattable avec blocage de sécurité.

Kippbare Kabine mit Sicherheitsklappen.

posto operatore

impianto idraulico ausiliario



Impianto idraulico ausiliario con presa di forza.

Auxiliary hydraulic circuit with power takeoff.

Circuit auxiliaire avec prise de force.

Hidraulische Hilfsanlage mit Kraffeingriff Instalación hidraulica.

ALLESTIMENTI ALLESTIMENTI

cabina ribaltabile

vano motore



Motorizzazioni affidabili di ultima generazione con bassi consumi e buon impatto ambientale.

Last generation motors with low consumption and good environmental impact.

Motorisation fiable de dernière génération, consommant peu, et faiblement polluant pour l'environnement

Motorisierung von letzter Generation mit niedrigem Kraftstoffverbrauch und gutem Umwelteinfluss.



José Ruela, Lda.

Estrada de Manique, 19 · 1750-166 LISBOA

Tel.: 217 542 320 (Chamada para rede fixa nacional)

aluguer@joseruela.pt · www.joseruela.pt

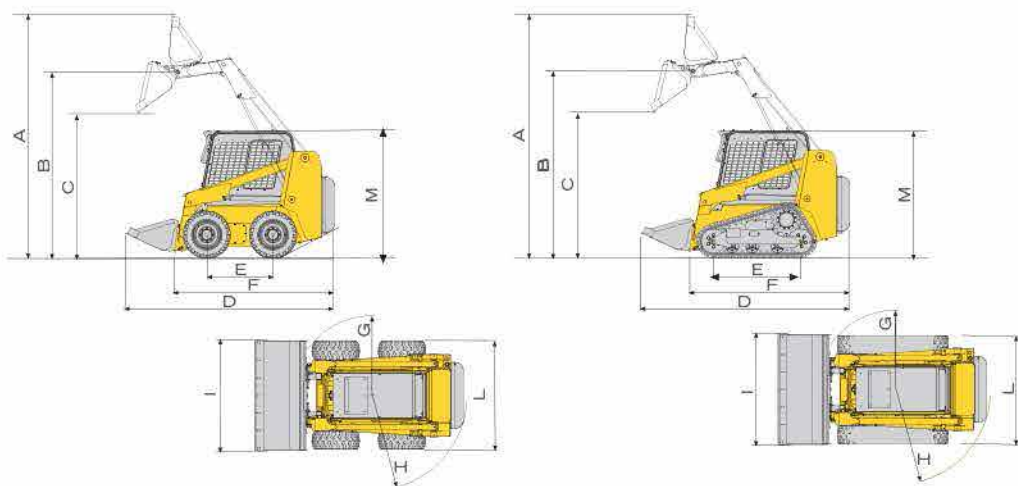

	A	B	C	D	E	F	G	H	I	L	M
635	3.450	2.630	1.950	2.910	810	2.230	1.770	1.320	1.250	1.220	1.850
755	3.745	2.870	2.250	3.239	933	2.547	1.880	1.530	1.524	1.511	1.979
865	3.767	2.891	2.281	3.239	1.016	2.547	1.956	1.487	1.676	1.651	1.981
985	4.023	3.073	2.390	3.500	1.067	2.769	1.295	1.626	1.829	1.824	2.045
T865	3.767	2.891	2.281	3.239	1.275	2.547	1.956	1.487	1.676	1.665	1.978

caractéristiques techniques

technische karakteristiken

Caractéristique Techniques		635	755	865	985	T865
Poids en orde de marche	Kg.	2.000	2.500	2.700	3.150	3.400
Charge utile nominale	Kg.	550	612	680	908	1.030
Charge de basculement	Kg.	1.100	1.224	1.360	1.816	2.060
Moteur diesel Kubota cc.		1.647	2.197	2.000T	3.300	2.000T
Puissance de réglage	KW tr/min.	25,4 2.800	34,6 2.800	43,5 2.800	64 2600	43,5 2.800
Pompe hydrostatique	bar lt/min.	300 2x78	345 2x113	345 2x113	350 2x130	34,5 2x113
Pompe de service	bar lt/min.	180 56	180 70	180 70	172 72	180 70
Vitesse de déplacement	km/h	0-10,5	0-11	0-11,5	0-10,5/16	0-7,5/11,5
Pneumatiques-patins de chenilles		27x8,5-15	10-16,5	10-16,5	12-16,5	320x86x48
Réservoir huile/gasoil	lt.	25/28	38/66	38/66	55/87	38/66

Betriebscharakteristiken		635	755	865	985	T865
Gewicht	Kg.	2.000	2.500	2.700	3.150	3.400
Nutzlast	Kg.	550	612	680	908	1.030
Kipplast	Kg.	1.100	1.224	1.360	1.816	2.060
Dieselmotor Kubota cc.		1.647	2.197	2.000T	3.300	2.000T
Leistung	KW rpm	25,4 2.800	34,6 2.800	43,5 2.800	64 2600	43,5 2.800
Hydrostatische pumpen	bar lt/min.	300 2x78	345 2x113	345 2x113	350 2x130	34,5 2x113
Getriebepumpen	bar lt/min.	180 56	180 70	180 70	172 72	180 70
Geschwindigkeit	km/h	0-10,5	0-11	0-11,5	0-10,5/16	0-7,5/11,5
Kettenbreite		27x8,5-15	10-16,5	10-16,5	12-16,5	320x86x48
Öl / Gasöltank	lt.	25/28	38/66	38/66	55/87	38/66



José Ruela, Lda.

Estrada de Manique, 19 · 1750-166 LISBOA

Tel.: 217 542 320 (Chamada para rede fixa nacional)

aluguer@joseruela.pt · www.joseruela.pt



ACCESSORI

accessories accessoires zubehörteil



José Ruela, Lda.

Estrada de Manique, 19 · 1750-166 LISBOA

Tel.: 217 542 320 (Chamada para rede fixa nacional)

aluguer@joseruela.pt · www.joseruela.pt



mischschaufel
godet mélangeuse
mixing bucket

benna miscelatrice



palettengabeln
couple fourches
fork pallet

coppia forche



erdbohrer
tarière
auger

trivella



grabenfräse
excavatrice à chaîne
digger with chain

scavatrice a catena



hydraulikhammer
brise roche
hammer

martellone

A C C E S S O R I A C C E S S O R I

fresa per asfalto

asphalt grinder
fraise pour asphalte
asphaltfräse

lama sgombra neve

snow plow
lame chasse-neige
schneeräumschild

spazzatrice

sweeper
balayeuse
kehrmaschine

ruote antiforatura

anti-puncture tyres
roues anti-crevaison
vollgummireifen

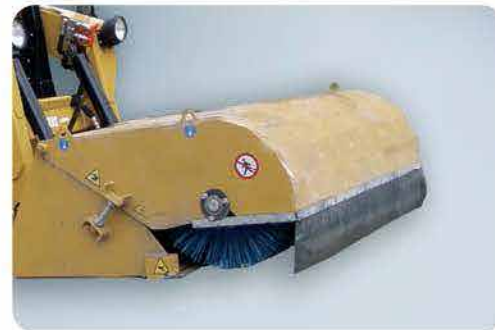

José Ruela, Lda.

Estrada de Manique, 19 · 1750-166 LISBOA

Tel.: 217 542 320 (Chamada para rede fixa nacional)

aluguer@joseruela.pt · www.joseruela.pt